

KBAC SERIES

ADJUSTABLE FREQUENCY DRIVES
FOR 3-PHASE AC MOTORS
NEMA-4X / IP-65

Washdown and Watertight for Indoor and Outdoor use

Models KBAC-24D, 27D, 29, 45, 48

Rated for 208-230 and 400/460 Volt 50 & 60 Hz

3-Phase AC Induction Motors from Subfractional thru 5 HP

Operates from 115, 208/230, and 400/460 Volt 50/60 Hz AC Line

TYPICAL APPLICATIONS



• Conveyors • Feeders • HVAC • Pumps

• Portable Equipment used with GFCIs¹



Industrial Die-Cast
Aluminum Enclosure
with Hinged Cover

CUSTOM SOFTWARE

All models can be factory programmed for applications that require special switching, timing, PLC functions, and GFCI operation.

STANDARD FEATURES

- **Industrial Duty Die-Cast Aluminum Case with Hinged Cover:** Available in dark gray finish or FDA approved white finish.
- **Simple to Operate:** Does not require programming. Uses trim pots and jumpers, which are factory set for most applications.
- **Motor HP Selection Jumper:** Allows the drive to be used on a wide range of motor horsepower without recalibration.
- **Diagnostic LEDs:** Power on (POWER) and drive status (STATUS).
- **Run/Fault Relay Output Contacts:** Can be used to turn on or off equipment or to signal a warning if the drive is put into the Stop Mode or a fault has occurred.
- **Start/Stop Switch:** Provides electronic start and stop functions.
- **Barrier Terminal Block:** Facilitates wiring of motor, AC line, and Run/Fault Relay Output Contacts.
- **Jumper Selection of Drive Output Frequency:** Increases the motor speed up to two times the rated RPM.
- **Ride-Through:** Provides smooth recovery to the previous set speed during a momentary power loss (of less than 2 seconds).
- **Holding Torque at Zero Speed:** Resists motor shaft rotation when the drive is in Stop Mode.
- **Compatible with GFCIs (with optional software).**

PERFORMANCE FEATURES

- **Power Start™:** Provides more than 200% starting torque which ensures startup of high frictional loads.
- **Slip Compensation with Static Auto-Tune and Boost:** Provides excellent load regulation over a wide speed range.
- **Speed Range:** 60:1

PROTECTION FEATURES

- **Motor Overload (I²t) with RMS Current Limit:** Provides motor overload protection which prevents motor burnout and eliminates nuisance trips.²
- **Electronic Inrush Current Limit (EICL™):** Eliminates harmful inrush AC line current during startup.
- **Short Circuit:** Shuts down the drive if a short circuit occurs at the motor (phase-to-phase).
- **Regeneration:** Eliminates tripping due to high bus voltage caused by rapid deceleration of high inertial loads.
- **Undervoltage and Overvoltage:** Shuts down the drive if the AC line input voltage goes above or below the operating range.
- **MOV Input Transient Suppression.**
- **Microcontroller Self Monitoring and Auto-Reboot.**

TRIMPOT ADJUSTMENTS

- **Minimum Speed (MIN)**
- **Deceleration (DECEL)³**
- **Boost (BOOST)**
- **Maximum Speed (MAX)**
- **Slip Compensation (COMP)**
- **Jog (JOG)**
- **Acceleration (ACC)**
- **Current Limit (CL)**

DESCRIPTION

The KBAC Adjustable Frequency Drives are variable speed controls housed in a rugged NEMA-4X / IP-65 washdown and watertight die-cast aluminum enclosure. They are designed to operate 208 – 230 and 400/460 Volt 50 & 60 Hz 3-phase AC induction motors from subfractional thru 5 HP. The sine wave coded Pulse Width Modulated (PWM) output operates at a carrier frequency of 16 kHz, which provides high motor efficiency and low noise. Adjustable Linear Acceleration and Deceleration make the drive suitable for soft-start applications.

Due to its user-friendly design, the KBAC is easy to install and operate. Tailoring to specific applications is accomplished with selectable jumpers and trim pots, which eliminate the computer-like programming required on other drives. However, for most applications no adjustments are necessary. For more advanced programming, PC based Drive-Link™ software is available.

Main features include adjustable RMS Current Limit and I²t Motor Overload Protection.² In addition, Adjustable Slip Compensation with Static Auto-Tune and Boost provides high torque and excellent load regulation over a wide speed range. Power Start™ delivers over 200% motor torque to ensure startup of high frictional loads. Electronic Inrush Current Limit (EICL™) eliminates harmful AC line inrush current. A Run/Fault Relay is provided, which can be used to turn on or off equipment or to signal a warning if the drive is put into the Stop Mode or if a fault has occurred. The drive is suitable for machine or variable torque (HVAC) applications. Also, a jumper is provided for selection of Regenerative or DC Injection Braking.

Standard front panel features include diagnostic LEDs for “Power On” and “Drive Status”, a Start/Stop Switch, and a Main Speed Potentiometer. Other features include a Barrier Terminal Block to facilitate wiring of the AC line and motor, adjustable trim pots (MIN, MAX, ACCEL, DECEL, COMP, CL, JOG, BOOST), customer selectable jumpers (Line Voltage (dual voltage models only), Motor Horsepower, Automatic Ride-Through / Manual Start, Motor Frequency, Frequency Multiplier, Fixed/Adjustable Boost, Regenerative/Injection Braking, “Run” or “Fault” Output Relay Operation, NO/NC Stop Contact, Constant/Variable Torque, I²t Overload Selection).

Optional accessories include: Forward-Stop-Reverse Switch, On/Off AC Line Switch, Run-Stop-Jog Switch, Signal Isolator, Auto/Manual Switch, Class “A” AC Line Filter, Multi-Speed Board, Programming Kit, Modbus Communication Module, and Liquidtight Fittings. A connector is provided for easy installation of accessories.

Custom software: All models can be factory programmed for applications which require special timing, PLC functions, and GFCI operation. Contact our Sales Department.

* Requires CE approved RFI Filter. See AC Line Filters, in Optional Accessories.

Notes: 1. Requires optional software. 2. UL approved as an electronic overload protector for motors.

3. When the drive is set for DC Injection Braking, the DECEL Trim pot is used to adjust the braking intensity and time.



Automation and Control

TABLE 1 – GENERAL PERFORMANCE SPECIFICATIONS

Description	Specification	Factory Setting
115 Volt AC Line Input Voltage Operating Range (Volts AC)	115 (±15%)	—
208/230 Volt AC Line Input Voltage Operating Range (Volts AC)	208 (-15%) / 230 (+15%)	—
400/460 Volt AC Line Input Voltage Operating Range (Volts AC)	380 (-15%) – 460 (+15%)	—
Maximum Load (% Current Overload for 2 Minutes)	150	—
Carrier, Switching Frequency (kHz)	16, 8	—
Signal Following Input Voltage Range ¹ (Volts DC)	0 – 5	—
Output Frequency Resolution (Bits, Hz)	10, .06	—
Minimum Speed Trimpot (MIN) Range (% Frequency Setting)	0 – 40	0
Maximum Speed Trimpot (MAX) Range (% Frequency Setting)	70 – 110	100
Acceleration Trimpot (ACCEL) and Deceleration Trimpot (DECEL) Range (Seconds)	.3 – 20	1.5
Boost Trimpot (BOOST) Range (Volts/Hz)	0 – 30	5
Slip Compensation Trimpot (COMP) Range at Drive Rating (Volts/Hz)	0 – 3	1.5
Current Limit Trimpot (CL) Range (% Full Load)	40 – 200	160
Jog Trimpot (JOG) Range (% Frequency Setting)	0 – 100	35
Motor Frequency Setting (Hz) (Jumper J5)	50, 60	60
Output Frequency Multiplier (1X, 2X) (Jumper J4) ²	1, 2	1
Minimum Operating Frequency to Motor (Hz)	0.3	—
Speed Range (Ratio)	60:1	—
Speed Regulation (30:1 Speed Range, 0 - Full Load) (% Base Speed) ³	2.5	—
Overload Protector Trip Time for Stalled Motor (Seconds)	6	—
Undervoltage/Overvoltage Trip Points for 115 Volt AC Line Input (±5%) (Volts AC) ⁴	76 – 141	—
Undervoltage/Overvoltage Trip Points for 208/230 Volt AC Line Input (±5%) (Volts AC) ⁴	151 – 282	—
Undervoltage/Overvoltage Trip Points for 400/460 Volt AC Line Input (±5%) (Volts AC) ⁴	302 – 567	—
Run/Fault Relay Output Contact Rating (Amps at 30 Volts DC, 125 Volts AC, 250 Volts AC)	1, 0.5, 0.25	—
Operating Temperature Range (°C / °F)	0 – 40* / 32 – 104	—
Operating Humidity Range (% Relative, Non Condensing)	0 – 95	—
Storage Temperature (°C / °F)	-25 – +85 / -13 – +185	—

Notes: 1. Requires an isolated signal. If a non-isolated signal is used, or if using 0 to ±2.5 thru 0 to ±25 Volts DC, or 4 – 20 mA DC signal inputs, install the SIAC – Signal Isolator (Part No. 9600). 2. Allows the motor to operate up to two times the rated RPM. Constant horsepower will result when operating the drive in the “X2” mode above the motor rated frequency. 3. Dependent on motor performance. 4. Do not operate the drive outside the specified AC line input voltage operating range.

*All models [except Model KBAC-29 (1P)] are rated at 40 °C, maximum ambient temperature, at the Rated Load Current. Model KBAC-29 (1P) is rated at 35 °C.

TABLE 2 – ELECTRICAL RATINGS

Model No.	Part No.		AC Line Input			Fuse or Circuit Breaker Rating (Amps)	Drive Output			Motor Horsepower Selection ³ (Jumper J2)					Net Wt.	
	Gray	White ¹	Volts AC (50/60 Hz)	Phase (φ)	Maximum Current (Amps AC)		Voltage Range (Nominal) (Volts AC)	Maximum Continuous Load Current ² (RMS Amps/Phase)	Maximum Horsepower (HP (kW))						lbs	kg
KBAC-24D	9987	9988	115	1	16	20	0 – 230	3.6	1 (.75)	1	3/4	1/2	1/4	1/8	5.9	2.7
			208/230	1	10	15	0 – 230									
KBAC-27D ⁴	9520	9521	115	1	22	25	0 – 230	5.5	1½ (1.13)	—	1½	1	3/4	1/2	10.3	4.7
			208/230	1	15	20	0 – 230	6.7	2 (1.5)	2						
KBAC-29 (1P) ⁵	10001	10002	208/230	1	20.5	25	0 – 230	9.0	3 (2.25)	3	2	1½	1	3/4	10.3	4.7
KBAC-29 ⁶	9528	9529	208/230	1	15	20	0 – 230	6.7	2 (1.5)	—	2	1½	1	3/4	10.3	4.7
				3	10.8	15	0 – 230	9.0	3 (2.25)	3						
KBAC-45 ⁷	9530	9531	400/460	3	5.3	10	0 – 400/460	4.6	3 (2.25)	3	2	1½	1	3/4	10.3	4.7
KBAC-48 ⁷	9540	9541	400/460	3	9.6	10	0 – 400/460	8.3	5 (3.75)	5	3	2	1½	1	10.3	4.7

Notes: 1. White FDA approved finish. 2. For ambient temperatures above 40 °C, all drives are derated 2.5% per °C. 3. Bold indicates factory setting. Jumper J2 on Model KBAC-24D is labeled “1”, “3/4”, “1/2”, “1/4”, “1/8” (factory set to the “1” position). Jumper J2 on Model KBAC-27D is labeled “2”, “1½”, “1”, “3/4”, “1/2” (factory set to the “1½” position). Jumper J2 on Models KBAC-29, 45, 48 is labeled “A”, “B”, “C”, “D”, “E” (factory set according to the table). 4. Model KBAC-27D is rated 1½ HP maximum with 115 Volt AC line input and 2 HP maximum with 208/230 Volt AC line input. 5. Model KBAC-29 (1P) is rated 9.0 Amps at 35 °C, maximum, and derated to 8.3 Amps at 40 °C. 6. Model KBAC-29 is rated 2 HP maximum with single-phase AC line input and 3 HP maximum with 3-phase AC line input. 7. Models KBAC-45, 48 are rated 0 – 400 Volts AC for 50 Hz motor operation and 0 – 460 Volts AC for 60 Hz motor operation.

**FIGURE 1 – MODEL KBAC-24D
MECHANICAL SPECIFICATIONS (Inches/mm)**

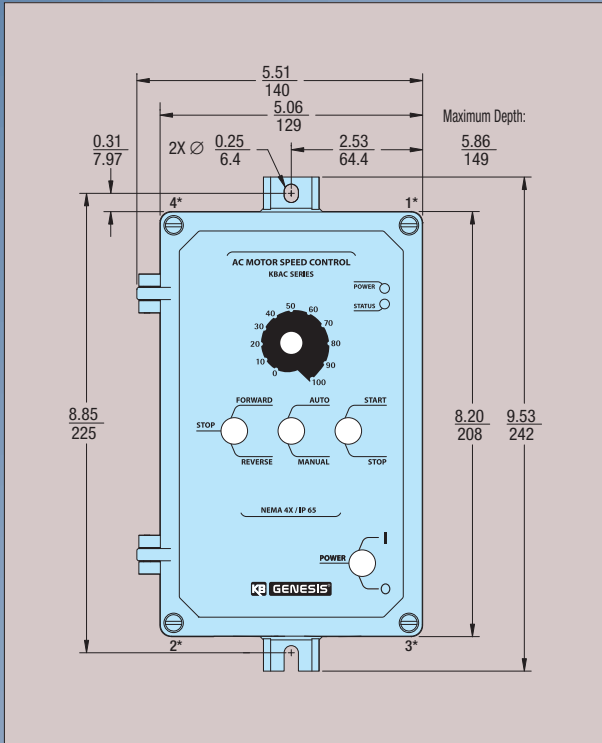

Contains 3 mounting holes for standard 1/2" liquidtight fittings
 * Tighten these screws, in the sequence shown, to 12 in-lbs (14 kg-cm).

**FIGURE 2 – MODELS KBAC-27D, 29, 45, 48
MECHANICAL SPECIFICATIONS (Inches/mm)**

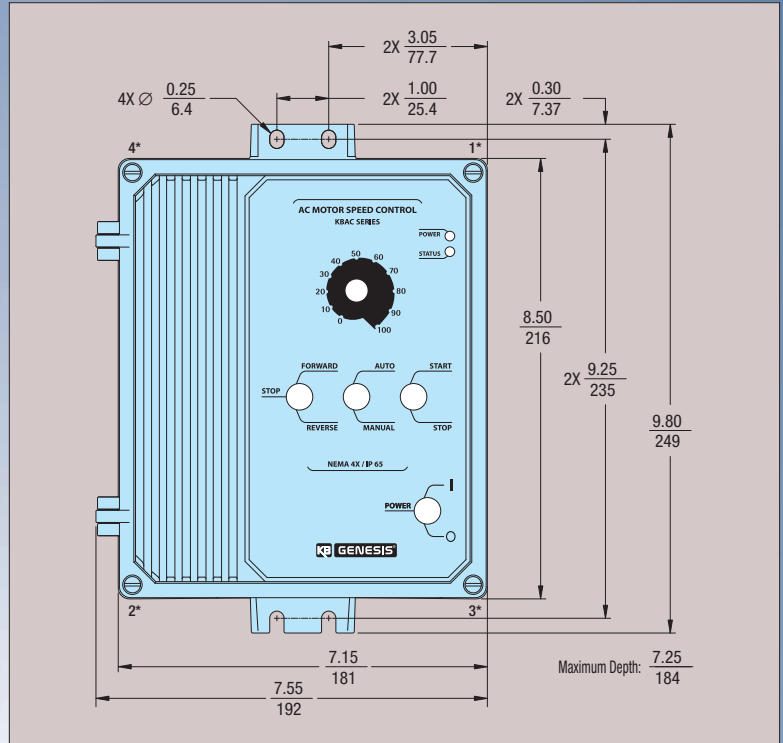

Contains 2 mounting holes for standard 1/2" liquidtight fittings and 1 mounting hole for standard 3/4" liquidtight fitting.
 * Tighten these screws, in the sequence shown, to 12 in-lbs (14 kg-cm).

FIGURE 3 – CONTROL LAYOUT¹

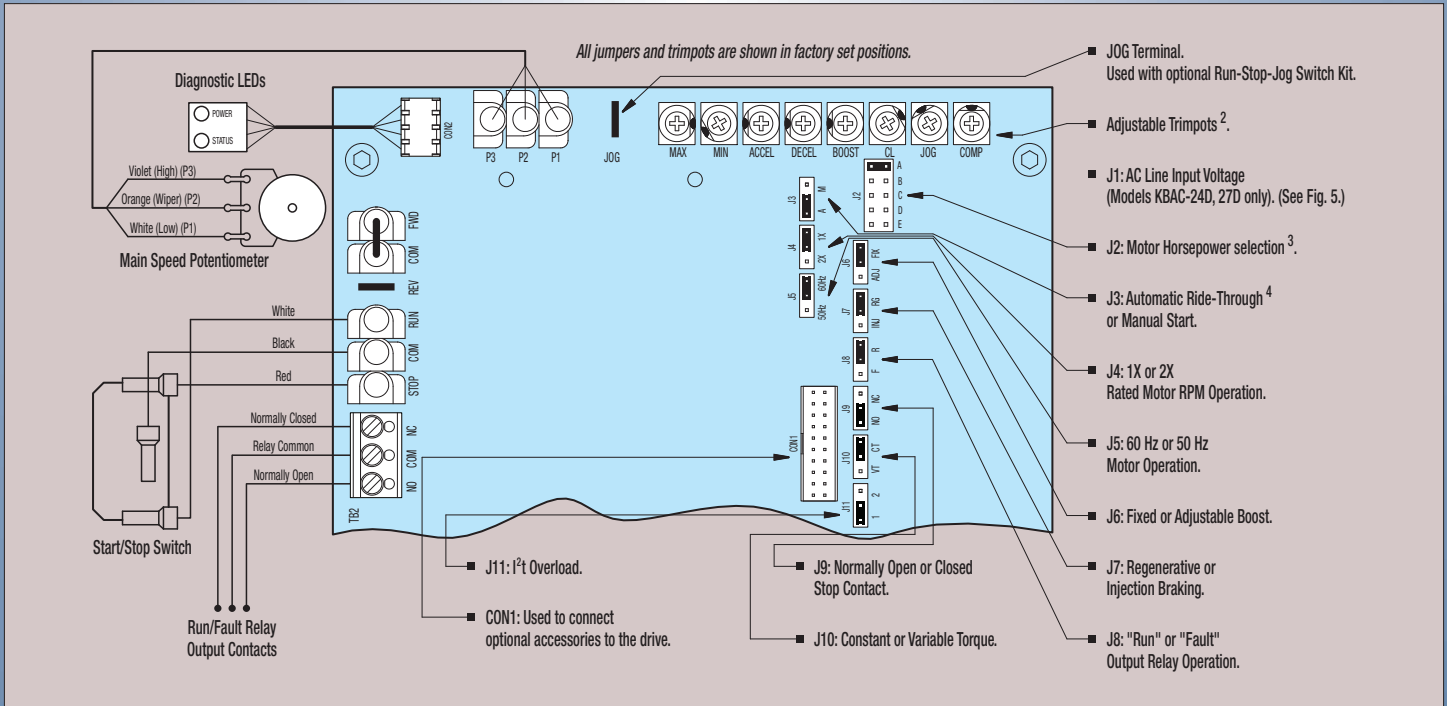

Notes: 1. Layout of Model KBAC-24D varies slightly. 2. On Model KBAC-24D, the JOG and COMP Trimpots are located vertically, along the right edge of the PC board (below the mounting screw). 3. On Model KBAC-24D, Jumper J2 is labeled "1", "3/4", "1/2", "1/4", "1/8" (factory set to the "1" position). On Model KBAC-27D, Jumper J2 is labeled "2", "1/2", "1", "3/4", "1/2" (factory set to the "1/2" position). On Models KBAC-29, 45, 48, Jumper J2 is labeled "A", "B", "C", "D", "E" (factory set according to Table 2, on page 2.) 4. On Model KBAC-24D, Jumper J3 is labeled "AUTO" and "MAN".



FIGURE 4 – MODELS KBAC-24D, 27D MOTOR & AC LINE INPUT CONNECTIONS

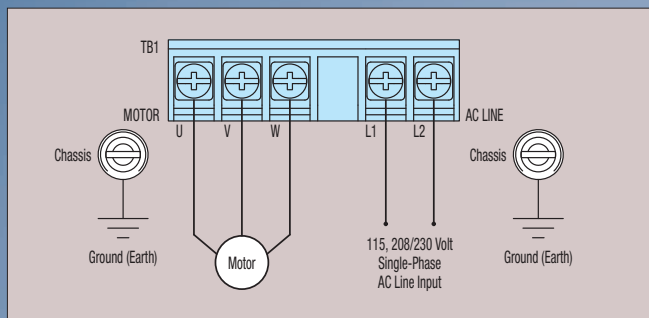
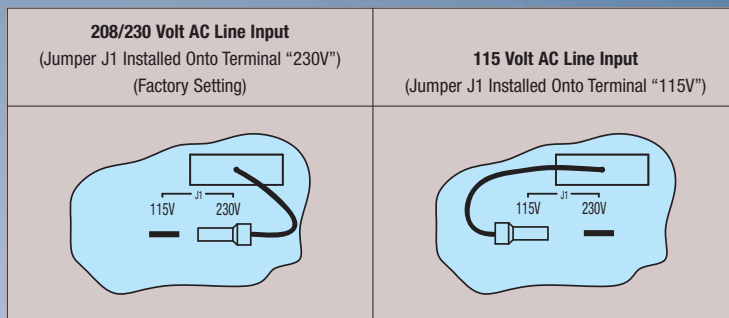

FIGURE 5 – MODELS KBAC-24D*, 27D AC LINE INPUT VOLTAGE SELECTION



* Layout of Model KBAC-24D varies slightly.

FIGURE 6 – MODELS KBAC-29, 45, 48 MOTOR & AC LINE INPUT CONNECTIONS

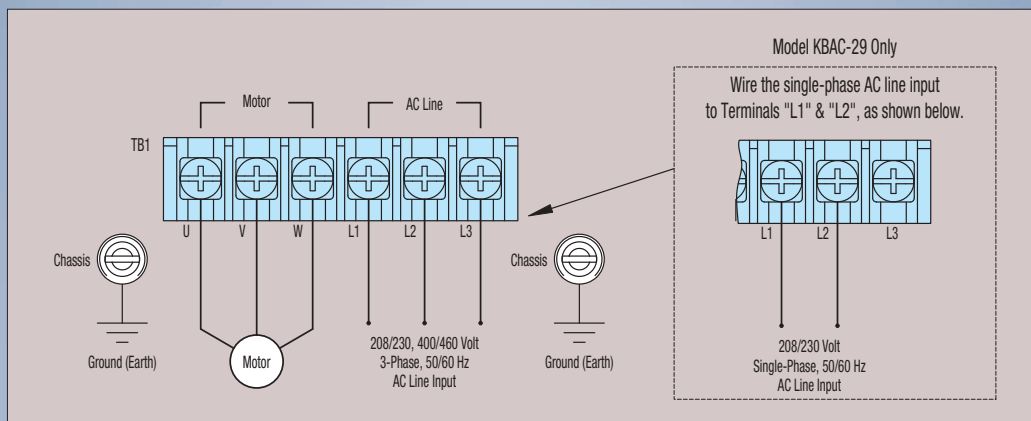

TABLE 3 – OPTIONAL ACCESSORIES

Description	Model KBAC-24D	Model KBAC-27D	Model KBAC-29	Model KBAC-29 (1P)	Model KBAC-45	Model KBAC-48
Forward-Stop-Reverse Switch – Provides motor reversing and stop functions. Mounts on the enclosure cover and is supplied with a switch seal to maintain liquidtight integrity.	9480	9480	9480	9480	9480	9480
On/Off AC Line Switch – Disconnects the AC line. Mounts on the enclosure cover and is supplied with a switch seal to maintain liquidtight integrity.	9482	9523	9532	9523	9532	9532
Run-Stop-Jog Switch – Selects speed setting from either the Main Speed Potentiometer or the JOG Trimpot. Mounts on the enclosure cover and is supplied with a switch seal to maintain liquidtight integrity.	9340	9340	9340	9340	9340	9340
Signal Isolator – Provides isolation between a non-isolated signal source and the drive. Mounts on the drive's PC board with four snap-ins.	9600*	9600*	9600*	9600*	9600*	9600*
Auto/Manual Switch – When used with the Signal Isolator, it selects remote process signal or the Main Speed Potentiometer. Mounts on the enclosure cover and is supplied with a switch seal to maintain liquidtight integrity.	9481	9481	9481	9481	9481	9481
AC Line Filter¹ – Provides Class A RFI (EMI) suppression. Installs onto the drive's PC board with quick-connect terminals.	Filter is used without On/Off AC Line Switch.		9515	**	9515	9515
	Filter is used with On/Off AC Line Switch.		9479	**	9479	9479
Multi-Speed Board – Provides multi-speed operation using external contacts or a PLC. Mounts on the drive's PC board with four snap-ins.	9489	9489	9489	9489	—	—
Liquidtight Fittings – Provide a liquidtight seal for wiring the drive. Kit includes three 1/2" and one 3/4" liquidtight fittings	9526	9526	9526	9526	9526	9526

Notes: 1. Complies with CE Council Directive 89/336/EEC Industrial Standard.

* **Warning!** It is highly recommended that the Signal Isolator (Part No. 9600) be installed when using the drive with external control signals.

** Future availability.



KB ELECTRONICS, INC.
 12095 NW 39th Street, Coral Springs, FL 33065-2516 • (954) 346-4900 • FAX (954) 346-3377
 Outside Florida Call Toll Free (800) 221-6570 • info@kbelectronics.com
 www.kbelectronics.com

COPYRIGHT © 2010 KB Electronics, Inc.
 (A42103) – Rev. E – 4/2010
 Print Code