

MULTI-SPEED BOARD

**KB Part No. 9503
For Model KBVF**

Provides (4) - User Selectable Speeds for the KBVF Adjustable Frequency Drive

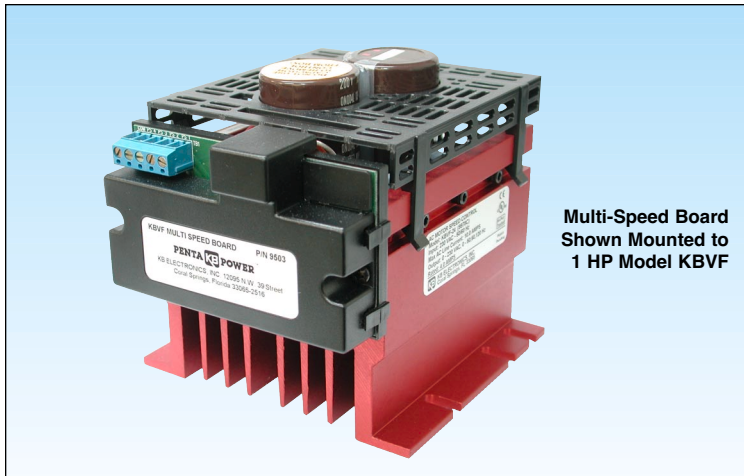

Multi-Speed Board Shown Mounted to 1 HP Model KBVF

STANDARD FEATURES

- **Multi-Speed Operation**
- **Trimpot Adjustments:** Provides adjustment of motor speed for each preset.
- **Forward/Reverse Jumpers:** Provides selection of forward or reverse motor direction for each preset.
- **Speed Range Jumpers (HI, LO):** Provides selection of high, low, or medium motor speed range for each preset.

GENERAL PERFORMANCE SPECIFICATIONS

Parameter	Specification
Preset Switch Types	Dry Contact* or Open Collector
Maximum Operating Current per Preset (milliamps DC)	1.5
Operating Temperature Range (°C)	0 – 50

*Note: Contacts must be isolated from the AC line.

TRIMPOT SPEED RANGE vs JUMPER SETTINGS

Parameter	LO Jumper	HI Jumper	Speed Range (% Base Speed)
Full Speed Range	Installed	Installed	0 - 100
High Speed Range	Not Installed	Installed	50 - 100
Low Speed Range	Installed	Not Installed	0 - 50
Medium Speed Range	Not Installed	Not Installed	33 - 66

CONNECTION DIAGRAMS

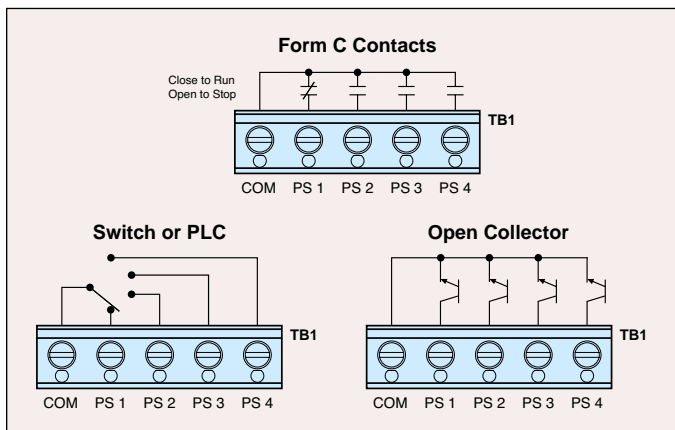

DESCRIPTION

The KBVF Multi-Speed Board (Part No. 9503) provides (4) - user selectable preset speeds to control a motor connected to the KBVF Adjustable Frequency Drive. A preset (PS 1, PS 2, PS 3, PS 4) is selected with a contact closure or open collector. The motor speed for each preset is adjustable via trimpot settings which can be fine tuned by using the HI-LO range jumpers. Motor direction is set by the position of Jumper R/F (forward/reverse) which is provided for each preset. Connections to the Multi-Speed Board are made via a barrier terminal block.

CONTROL LAYOUT & MECHANICAL SPECIFICATIONS (inches/mm)

